



Thank you for purchasing from the **Favoured Media shelving** for conference rooms!

The design of this shelving allows easy installation by a competent adult.

The simple assembly requires a drill bit to suit the rawl plugs (8mm at time of writing) a measure and a cross headed screwdriver.



Please take a few moments to read these instructions to get the most from the product.

ASSEMBLY INSTRUCTIONS

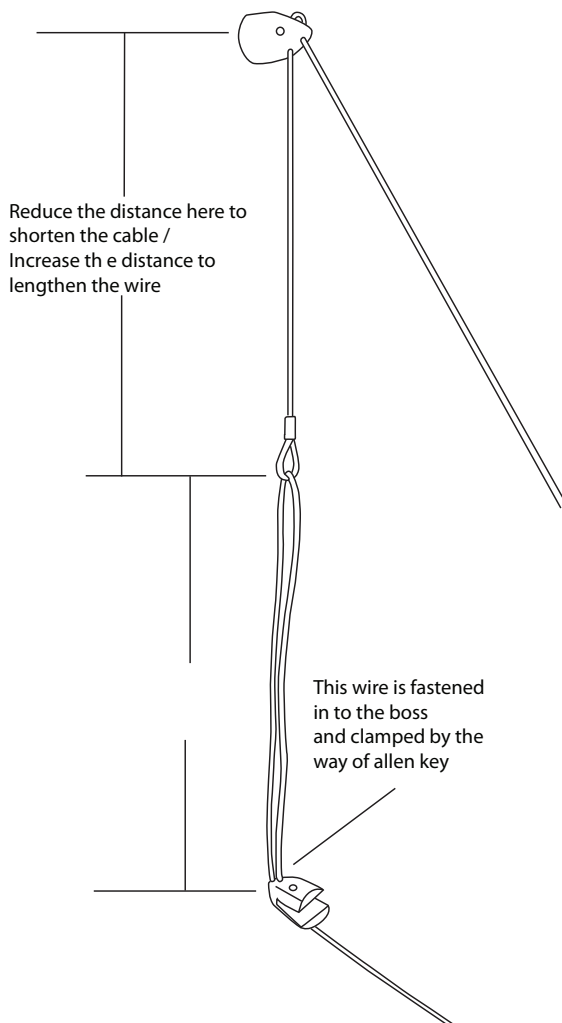

1. Starting two level holes into a SOLID wall, position the holes so that they are 25mm in from the edge of the glass i.e. 600mm glass is 550mm centre spacing. REMEMBER that the height of the shelf is always below the holes by approximately the depth of the glass.
2. Slide the grub screw over the screw, then screw the rawl plugs into the wall, to loosely clamp the grub screw to the wall. This will give a thread for the next component to fasten to.
3. Now screw the top boss onto the stud in the wall.
4. Now thread the end of the wire without the loop upwards through the back hole.
5. Now take the wire down through the front hole, taking care not to Kink the wire as it needs adjustment in the future. Now the wire must go UPWARDS through the hole nearest the point (with the nylon grub screw facing down) and thread it through the loop end of the wire above.

(assembly instructions continued in next page)

The glass supplied is toughened to BS6206A for safety. In order to maximize this safety; please follow the following precautions.

- | | |
|---|--|
| 1. Replace any damaged glass with that of identical specification. | 6. Avoid subjecting the shelf to impact. |
| 2. Never place heavy objects onto the shelf. | 7. Never Sit or Stand on the shelf. |
| 3. Use a suitable non-abrasive glass cleaner. | 8. The shelf is not suitable for rough use |
| 4. Take care in positioning the shelving to avoid it being knocked. | 9. In the unlikely event of breakage, a competent person must clear thoroughly the area of sharp shards of glass, which may cut. |
| 5. Never place hot pans onto the shelf. | |



Thank you for purchasing from the **Favoured Media shelving** for conference rooms!

page 2

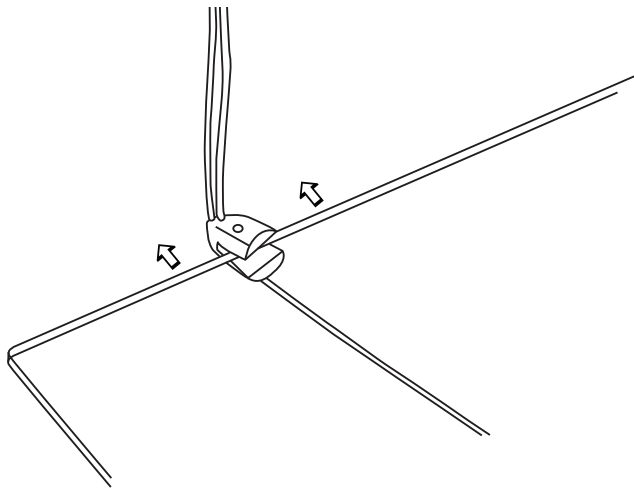

6. The glass can now be positioned into the slot, and the wire brought around the front of the glass. Ensure that both wires are secured in the grub screws and the nylon grub screws are securing the glass.
7. Adjust the shelf by increasing or decreasing the distance of the loop to the top threaded boss.

Thank you for purchasing the **Favoured Media shelving** for retail display!

The design of this shelving allows easy installation by a competent adult.

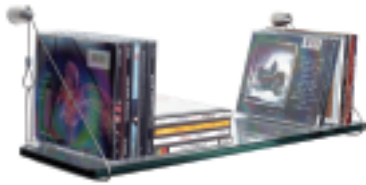

The simple assembly requires a drill bit to suit the rawl plugs (8mm at time of writing) a measure and a cross headed screwdriver.

Please take a few moments to read these instructions to get the most from the product.

ASSEMBLY INSTRUCTIONS

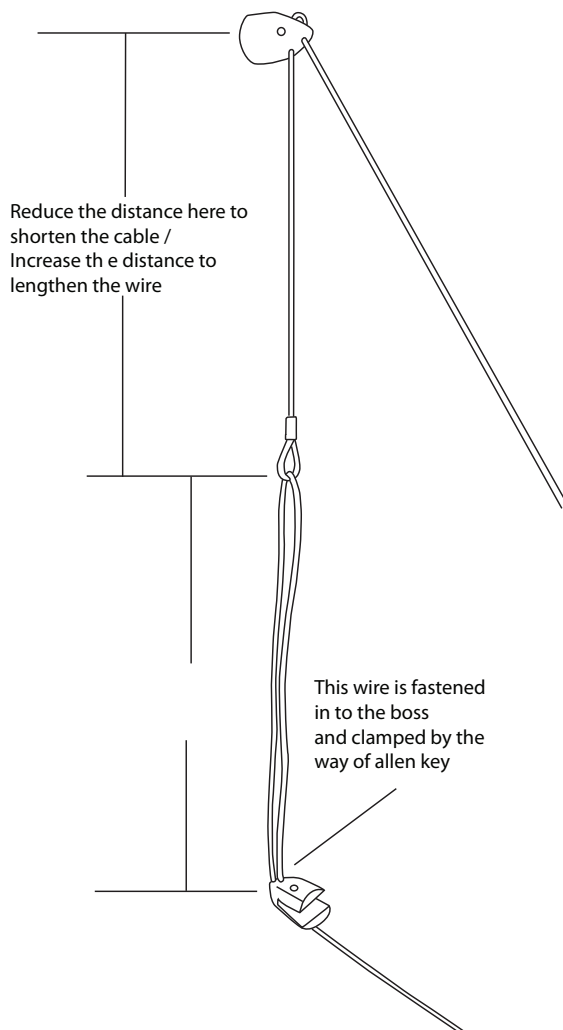

1. Starting two level holes into a SOLID wall, position the holes so that they are 25mm in from the edge of the glass i.e. 600mm glass is 550mm centre spacing. REMEMBER that the height of the shelf is always below the holes by approximately the depth of the glass.
2. Slide the grub screw over the screw, then screw the rawl plugs into the wall, to loosely clamp the grub screw to the wall. This will give a thread for the next component to fasten to.
3. Now screw the top boss onto the stud in the wall.
4. Now thread the end of the wire without the loop upwards through the back hole.
5. Now take the wire down through the front hole, taking care not to Kink the wire as it needs adjustment in the future. Now the wire must go UPWARDS through the hole nearest the point (with the nylon grub screw facing down) and thread it through the loop end of the wire above.

(assembly instructions continued in next page)

The glass supplied is toughened to BS6206A for safety. In order to maximize this safety; please follow the following precautions.

- | | |
|---|--|
| 1. Replace any damaged glass with that of identical specification. | 6. Avoid subjecting the shelf to impact. |
| 2. Never place heavy objects onto the shelf. | 7. Never Sit or Stand on the shelf. |
| 3. Use a suitable non-abrasive glass cleaner. | 8. The shelf is not suitable for rough use |
| 4. Take care in positioning the shelving to avoid it being knocked. | 9. In the unlikely event of breakage, a competent person must clear thoroughly the area of sharp shards of glass, which may cut. |
| 5. Never place hot pans onto the shelf. | |



Thank you for purchasing the **Favoured Media shelving** for retail display!

page 2

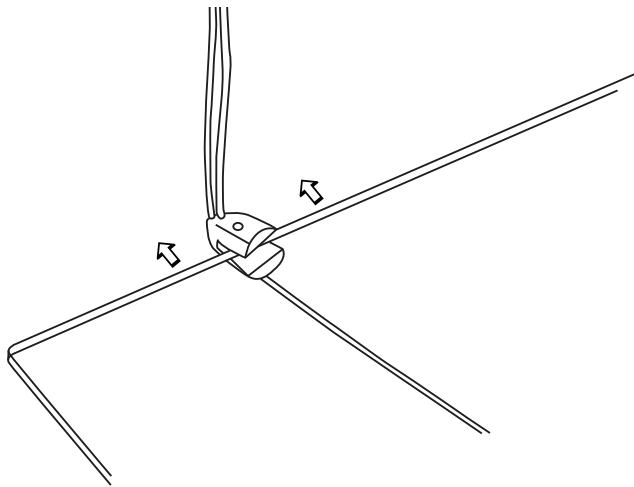

6. The glass can now be positioned into the slot, and the wire brought around the front of the glass. Ensure that both wires are secured in the grub screws and the nylon grub screws are securing the glass.
7. Adjust the shelf by increasing or decreasing the distance of the loop to the top threaded boss.